

TOA MEGAPHONE (WITH WHISTLE SIGNAL) ER-520W/(EU)

DESCRIPTION

Small in size and light in weight, the ER-520W megaphone can be easily carried by a single hand. It can also provide a whistle tone. Handle and microphone with anti-bacteria treatment improve hygiene and safety during use. The newly developed polyimide diaphragm is employed to ensure high sound quality.

SPECIFICATIONS

Power Source	R6P (AA) × 8 (12 V DC)
Rated Output	6 W
Maximum Output	10 W
Signal Sound	Whistle
Battery Life	Voice: Approx. 10 hours (JEITA)* Whistle: Approx. 30 minutes (JEITA)*
Audible Range (City areas)	Voice: Approx. 250 m (JEITA)* Whistle: Approx. 315 m (JEITA)*
Diaphragm	Polyimide film
Anti-bacteria Treatment	Mouth and handle
Operating Temperature	-10 °C to +40 °C
Finish	Horn: ABS resin, light gray Strap: Teton, black Handle, mouth and others: ABS resin, gray
Dimensions	160 (W) × 256 (H) × 260 (D) mm
Weight	650 g (without batteries)

Note: Batteries are optional.

* JEITA: Japan electronics and information technology industries association. (EIAJ TT-4501A)

APPEARANCE

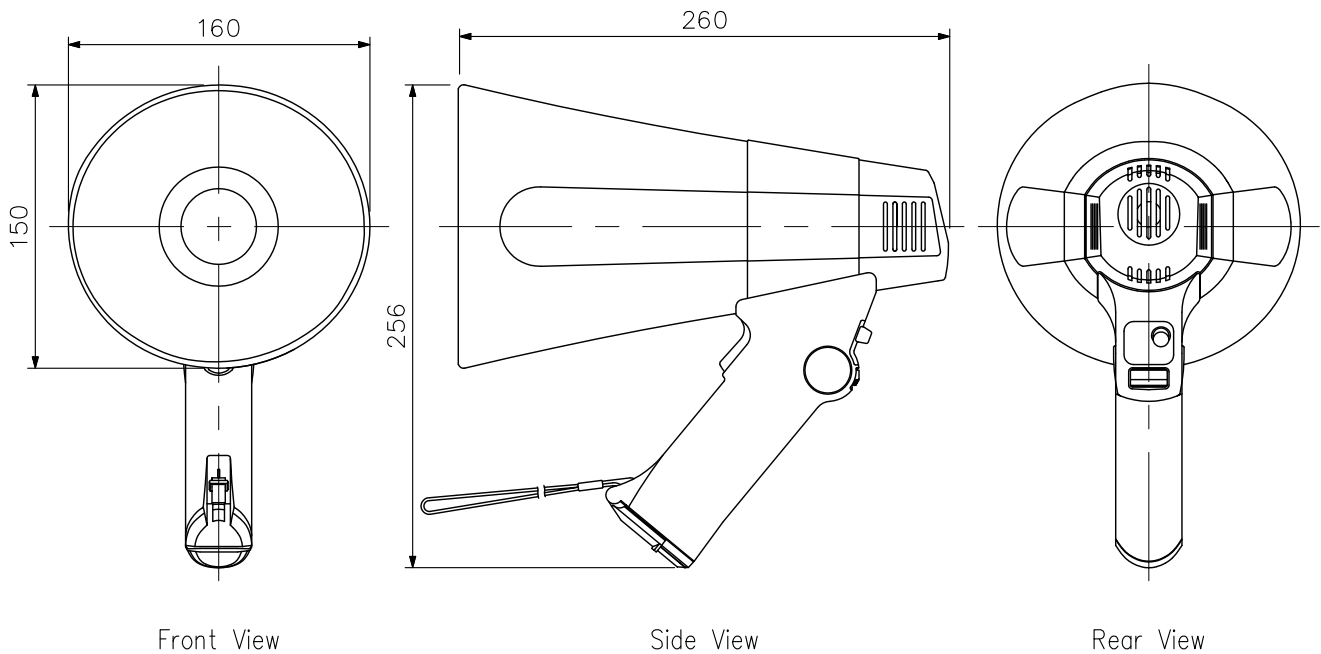

<Note on the audible range and battery life>

1. The indications of the audible range and battery life are based on the JEITA Standard*.
2. Audible Range presumes that the megaphone employs new batteries and is used on a quiet street. It varies depending on such conditions as battery consumption, ambient noise, wind direction and obstacles.
3. Battery Life assumes that megaphone is used for 30 minutes a day.

UNIT:mm SCALE:1/4